

**The Potential
Consequences of
Climate Variability
and Change**

Educational Product	
Educators	Grades 1-4

OVERVIEW

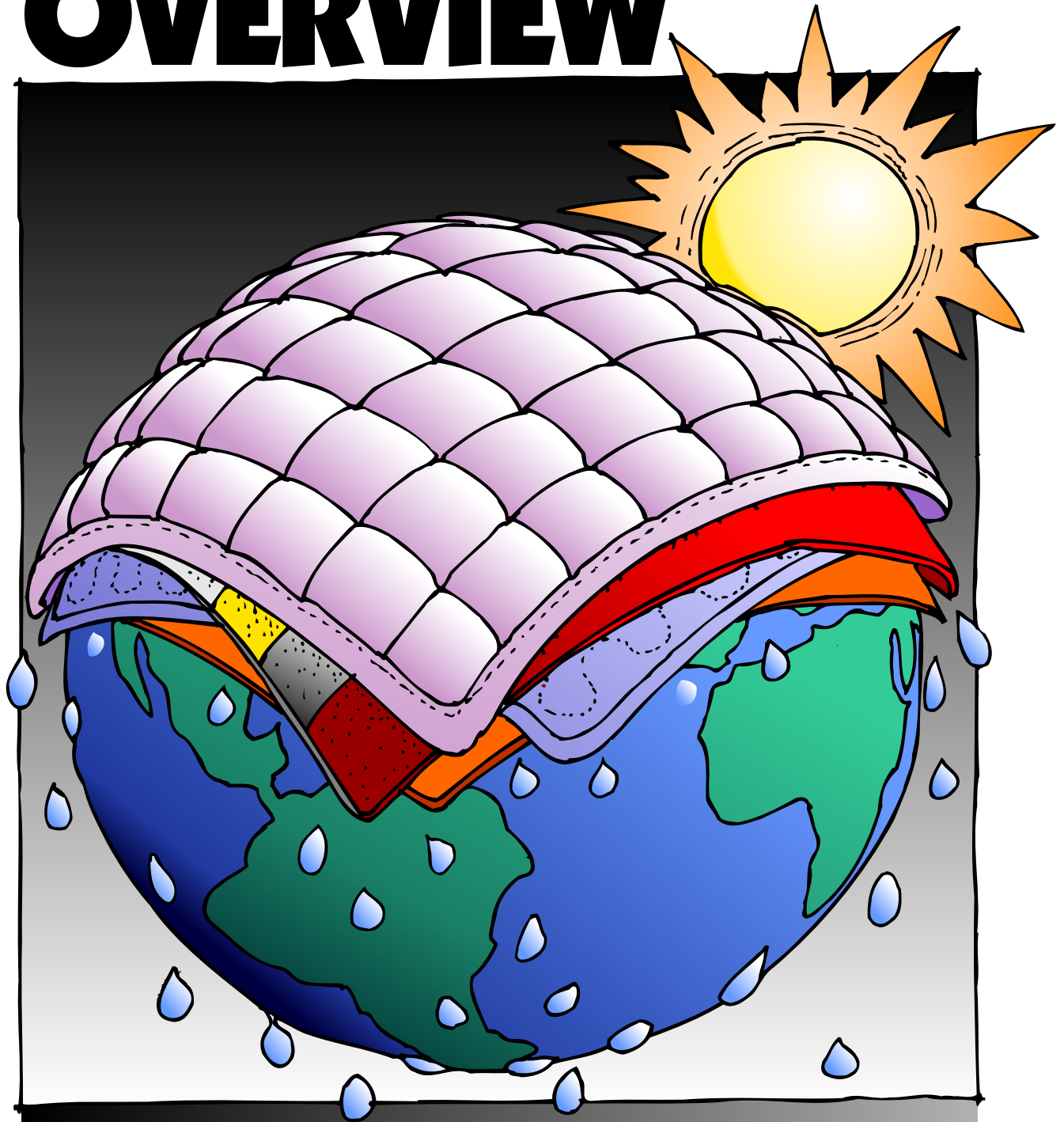

Too Many Blankets

This learning activity was developed to examine the potential impacts of climate variability and change. Each activity is part of an overall series entitled *The Potential Consequences of Climate Variability and Change*, which includes 1–12 teacher resources. Twelve modules (10 printed and 2 online resources) comprise the set and are presented below:

OVERVIEW

- Too Many Blankets (Grades 1–4)
- Global Balance (Grades 5–12)

AGRICULTURE

- El Niño (Grades 5–8)
This activity is provided in an online format only and is available at <http://ois.unomaha.edu/casde/casde/lessons/Nino/teacherp.htm>.
- The Great American Desert? (Grades 9–12)
This activity is provided in an online format only and is available at <http://ois.unomaha.edu/casde/casde/lessons/grass/teacherp.htm>.

COASTAL AREAS

- What Could a Hurricane Do to My Home? (Grades 5–8)
- What Is El Niño? (Grades 5–8,9–12)
- Coral Reefs in Hot Water (Grades 9–12)

FORESTS

- A Sticky Situation (Grades 5–8)
- Planet Watch 2000 (Grades 9–12)

HUMAN HEALTH

- Beyond the Bite: Mosquitoes and Malaria (Grades 5–8,9–12)
- Climate and Disease:A Critical Connection (Grades 9–12)

WATER

- Here, There, Everywhere (Grades 7–8,9–12)

The development of the activities was sponsored by the National Aeronautics and Space Administration and the Environmental Protection Agency, in support of the US Global Change Research Program. The Institute for Global Environmental Strategies implemented the effort. For more information, see <http://www.strategies.org>. For additional resources, please visit <http://teach.earth.com>—Resources for Teaching and Learning about Earth System Science..

Climate Variability & Change **OVERVIEW ACTIVITIES FOR 1–4 EDUCATORS**

Authored by:

Julia H. Berry, Science Teacher, St. Patrick's Episcopal Day School, Washington, DC.

Prepared by:

Stacey Rudolph, Senior Science Education Specialist, The Institute for Global Environmental Strategies, Arlington, VA.
Graphic Design by Susie Duckworth.

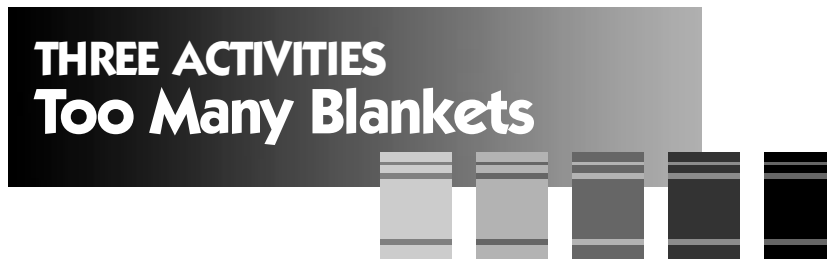

CONTENTS

Grade Levels; Time Required; Objectives; Disciplines Encompassed; Prerequisite Knowledge: Teacher.	2
Prerequisite Knowledge: Students	3
Key Terms and Concepts; Suggested Reading/Resources	4
Activity One: How Does the Make-up of the Atmosphere Affect Temperature?	5
Student Activity One Lab Sheets.	7
Activity Two: How Do Higher Temperatures Affect the Water Cycle?	11
Student Activity Two Lab Sheets.	12
Activity Three: What Will Happen if Climate Variability and Change Cause Glacier and Polar Ice Cap Melting?	20
Student Activity Three Lab Sheets	22
Appendix A: Bibliography	29
Appendix B: Assessment Rubric & Answer Keys	30
Appendix C: National Education Standards	35
Appendix D: Preliminary Experiments.	37

Too Many Blankets



This series of activities demonstrates some effects of rising levels of greenhouse gases on climate. Specifically, it shows how:

- An increase of heat-trapping gases in the atmosphere raises temperatures;
- Higher temperatures affect the water cycle; and
- Rising sea levels could affect coastal areas as a result of glacial and polar ice melt.

Although these activities are designed to teach specific skills and knowledge through scientific inquiry, their broader intent is to stimulate thought and discussion about the long-term impacts of a warmer planet.

GRADE LEVELS

Grades 1–4

TIME REQUIRED

Activities should be done over a two-week period.

OBJECTIVES

Through their participation in the three activities that follow, students will:

- Observe and describe changes within three ecosystem models as variables are changed;
- Explain the relationship between the models and the real world; and
- Make predictions about future climate changes and some of their potential impacts on Earth, based on these understandings.

DISCIPLINES ENCOMPASSED

- Earth Systems Science
- Environmental Science
- Geography
- Language Arts

- Mathematics
- Meteorology
- Physical Science
- Social Studies

PREREQUISITE KNOWLEDGE: TEACHER

To effectively teach about the effects of climate variability and change, teachers should have a solid understanding of the following concepts:

- The sun provides the heat and light energy that sustains life on Earth. It creates the weather we experience daily (for example, the cycle of precipitation and wind patterns) and the climate characteristics of the place where we live (tropical, sub-tropical, temperate, and polar regions).
- The atmosphere, which is virtually transparent to incoming sunlight, surrounds the Earth and helps trap heat near the Earth's surface, much as the glass over a greenhouse traps heat. Without our atmospheric "blanket," the Earth would be about 60 degrees F cooler in every season.
- The atmosphere consists of many kinds of molecules (nitrogen, oxygen, carbon dioxide, aerosols including water vapor, and others). These molecules absorb, emit, transmit, and reflect heat and light energy.
- Combustion, exhaust, and other by-products of human activities (aerosols) are contributing to the changing mix of molecules in the atmosphere. This change is causing our atmosphere to hold in more heat energy and has raised temperatures in every climate zone.
- A glacier is a large mass of ice formed on land. An iceberg is a large piece of ice that has broken off from a glacier and dropped into a large body of water. About 4/5 to 8/9 of an iceberg is below the water.

- Keep in mind that melting icebergs will not cause a rise in sea level, since they are already in the ocean. Melting glaciers, on the other hand, will cause a sea level rise, since they are land-based.
- Rising temperatures may cause changes in the Earth's climate. Effects might include drought, torrential rains, flooding, rising sea levels, and depletion of ground water. More positive effects could be increased plant production or warmer winters in northern cities.
- A list of preliminary experiments that will enhance student understanding is given in Appendix D.
- **IMPORTANT:** The enclosed lab sheets are to be used by Grade 3–4 students, and by 1–2 teachers to help organize their own observations and guide their discussions with students who have limited reading and calculating skills.

NOTE: These activities deal only with the effects of aerosols and gases on the Earth's temperature. The effect of albedo, due to cloud cover, is not discussed.

PREREQUISITE KNOWLEDGE: STUDENTS

Students must have the following skills and knowledge to complete this activity:

- The sun's heat creates our weather. It drives the water cycle and wind patterns. Students need to understand the basics of the water cycle, especially the concepts of evaporation and precipitation (see Figure 1).
- "Air is there." It consists of gas molecules and has mass. A simple way to demonstrate this idea is to show your students an "empty" paper lunch bag. When you ask them what is inside, most students will answer, "Nothing." Next, face each student with the opening of the bag about 18 inches from his or her face. Then, clap the bag between your hands. This forces air out of the bag and "squirts" the stu-

dent with "nothing." Now if you ask what was in the bag, your students will answer, "Air."

- The atmosphere consists of a mixture of molecules. It acts like a blanket to keep the Earth warm enough for us to live. Most of the components of our atmosphere are there naturally, but the activities of people living and working on the Earth have changed the mixture of gases and particles, increasing the amount of heat-trapping gases in the atmosphere. It is much like adding more blankets to your bed at night. The more blankets you add, the warmer you become. The more heat-trapping gases there are in the atmosphere, the more of the sun's energy it traps and the higher the temperatures rise.
- Weather is what happens outdoors everyday, whereas climate is the average weather in a particular place over the seasons of the year. Your students should be able to show which zones of the Earth are tropical, subtropical, temperate, and polar.

Figure 1. The Water Cycle

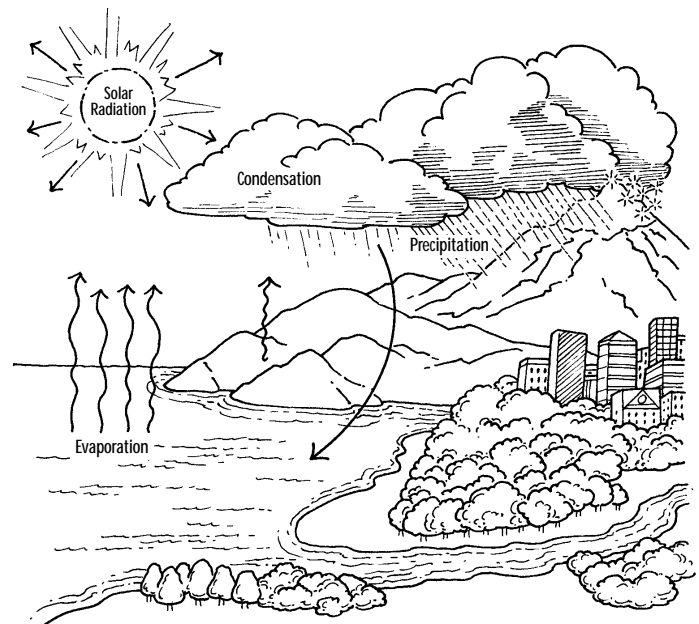

KEY TERMS AND CONCEPTS

The following terms and concepts will be presented in the following text and activities:

Atmosphere
Carbon dioxide
Climate
Condensation
Earth
Ecosystems
Erosion
Evaporation
Exhaust
Gases
Glaciers
Global warming
Greenhouse effect
Greenhouse gases
Iceberg
Mineralization
Particles
Polar ice
Pollution
Precipitation
Salinity
Sea rise
Solar radiation
Water cycle
Water vapor
Weather

SUGGESTED READING/RESOURCES

Listed below are several excellent books written for children and adults that provide greater detail about the complex concepts presented above.

Johnson, Rebecca L. 1990. *The Greenhouse Effect: Life on a Warmer Planet*. Lerner Publications Company. Minneapolis, MN.

Kahl, Jonathan D. W. 1998. *Hazy Skies: Weather and the Environment*. Lerner Publications Company. Minneapolis, MN.

Pringle, Laurence. 1990. *Global Warming: Assessing the Greenhouse Threat*. Arcade Publishing, Inc. New York, NY.

Stille, Darlene R. 1990. *A New True Book: The Greenhouse Effect*. Childrens Press. Chicago, IL.

ACTIVITY ONE

How Does the Make-up of the Atmosphere Affect Temperature?

This activity will answer the question: Does an increase in the amount of heat-trapping gases in the atmosphere cause the temperature on Earth to rise?

MATERIALS

- Two small aquarium tanks, a glass cover (a plastic cover or plastic food-wrap will work, but should not come in direct contact with the lamp)
- Water-resistant modeling compound
- Rocks and pebbles
- Small houses
- Figures
- Vehicles
- Two clamp lamps with 60-watt bulbs
- Tinted plastic wrap or transparency paper
- Two student thermometers
- Tape
- A clock
- Pencils
- A grease pencil or marker (optional)
- Student Activity One lab sheets

NOTE: The activities call for comparisons between more than one system. If you are able, setting up two tanks at one time can make for a much more effective comparative demonstration, especially for younger students for whom temperature readings in real numbers hold much less meaning. Otherwise, the activities can be run sequentially.

PROCEDURE

Step 1

Use the modeling compound, rocks, pebbles, houses, figures, and vehicles to create a small world inside aquariums. It should cover about half of the area inside each aquarium. Have your students help place the houses based on where they would most like to live. Be sure to build some inviting “beach-front” areas along the coasts and some potential building sites at higher elevations (see Figure 2).

Step 2

Tape the thermometer to the inside center of the front of the tanks so they can be read through the glass. Cover the top of Tank 2 with the glass cover and plastic wrap (see Figure 2). (*NOTE: Place the plastic wrap around the lamp bell, not under it. CAUTION: Material in direct contact with the bare bulb may catch fire. Explain to the students this is only being done to prevent the plastic wrap from catching on fire. In the “real” atmosphere, the sun’s rays pass directly through the atmosphere.*) Place a lamp over the center of each tank. Record the temperature on the **Student Activity One Lab Sheets** and turn on the lights. (You may wish to use a grease pencil or marker to mark the level of the thermometer at the start of the experiment.)

Figure 2. Tank Set-ups

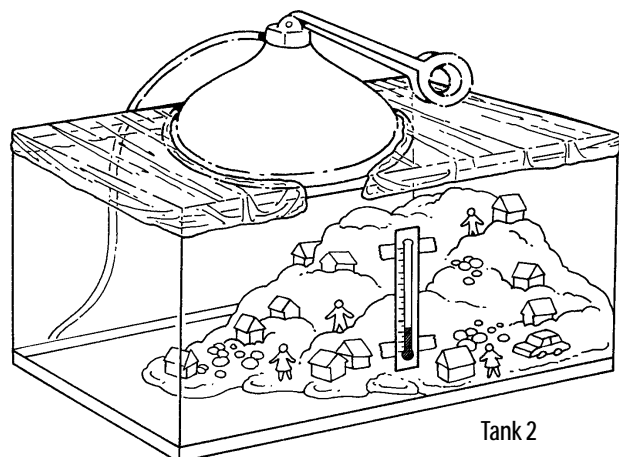
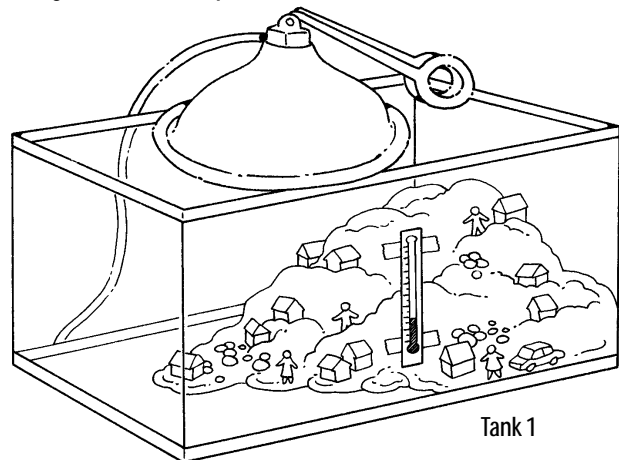

Step 3

Record the temperatures at 1,5,10,30,and 60-minute intervals on the lab sheets.

Step 4

Complete lab sheets.

CONCLUSION

- Discuss the differences in the temperatures in each tank;
- Ask why the tank with the plastic wrap on top got warmer;
- Ask why the temperature stopped rising after a little while;and
- Ask students to explain how this experiment is comparable to what is happening on Earth with greenhouse gases.

EXTENSIONS

1. Record the length of time it takes each tank to reach room temperature after the light is turned off. Then have the students answer the following questions:
 - Did the two tanks cool at the same rate? (No, the one with insulation cooled slower.)
 - Why was one much slower to cool? (The plastic wrap keeps in the heat.)
 - How is this comparable to Earth? (The atmosphere containing more heat-trapping gases keeps the Earth warmer.)
 - How would local climates change if this were to happen? (Temperatures would be warmer all year long, everywhere on the Earth;nighttime temperatures would be higher.)
2. Try this experiment with the plastic wrap, but without the glass cover. Then try it with the glass cover, but without the plastic wrap. Predict how and why the results may differ. Then compare the results with their predictions.

STUDENT ACTIVITY ONE LAB SHEET

How Does the Make-up of the Atmosphere Affect Temperature (Tank 1)?

Name _____

TEMPERATURE CHANGE FOR TANK 1

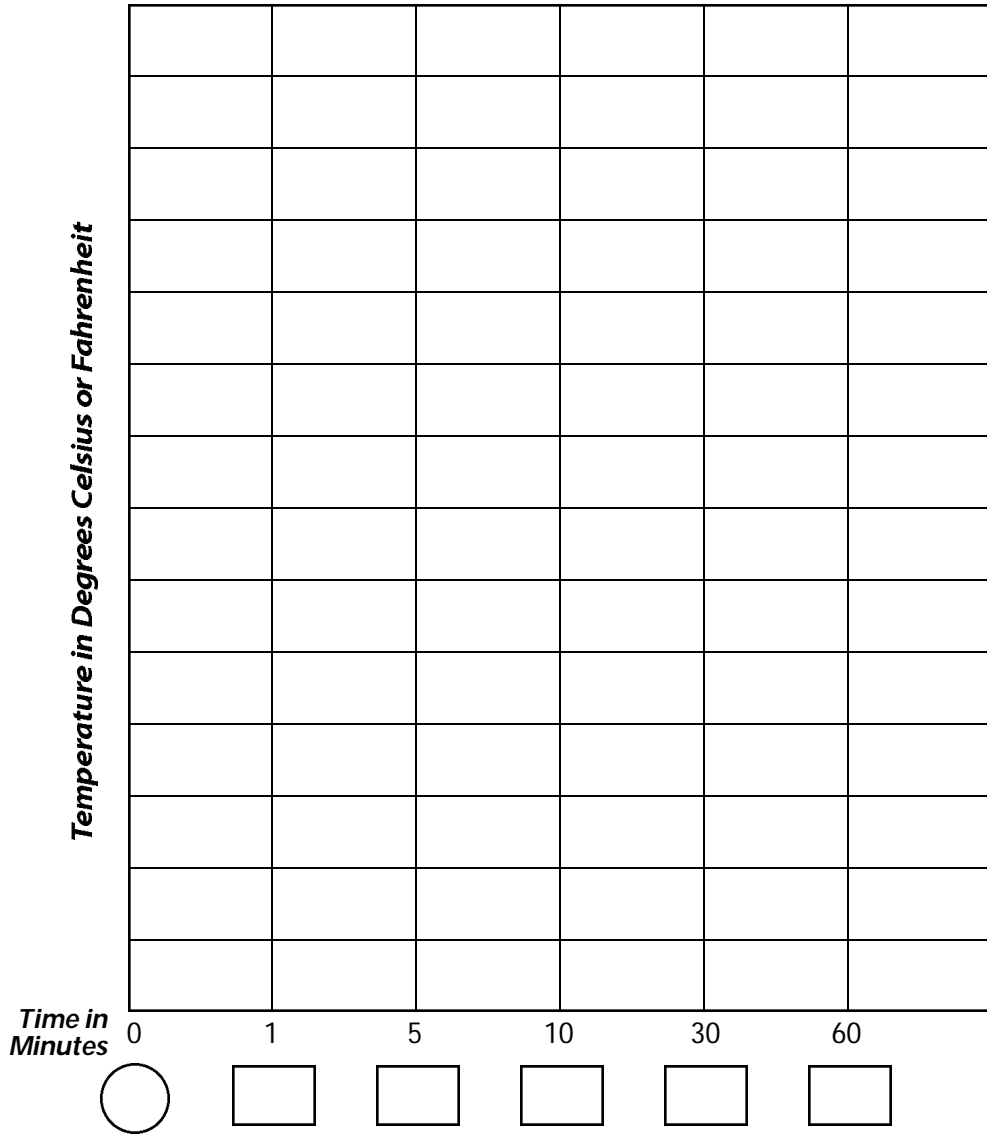

Final temperature - Starting temperature = Total temperature change

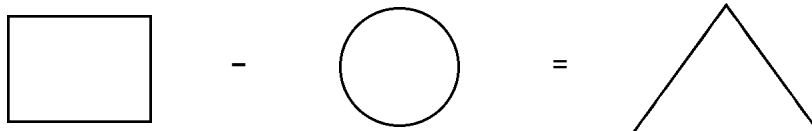

STUDENT ACTIVITY ONE LAB SHEET
How Does the Make-up of the Atmosphere Affect Temperature (Tank 2)?

Name _____

TEMPERATURE CHANGE FOR TANK 2

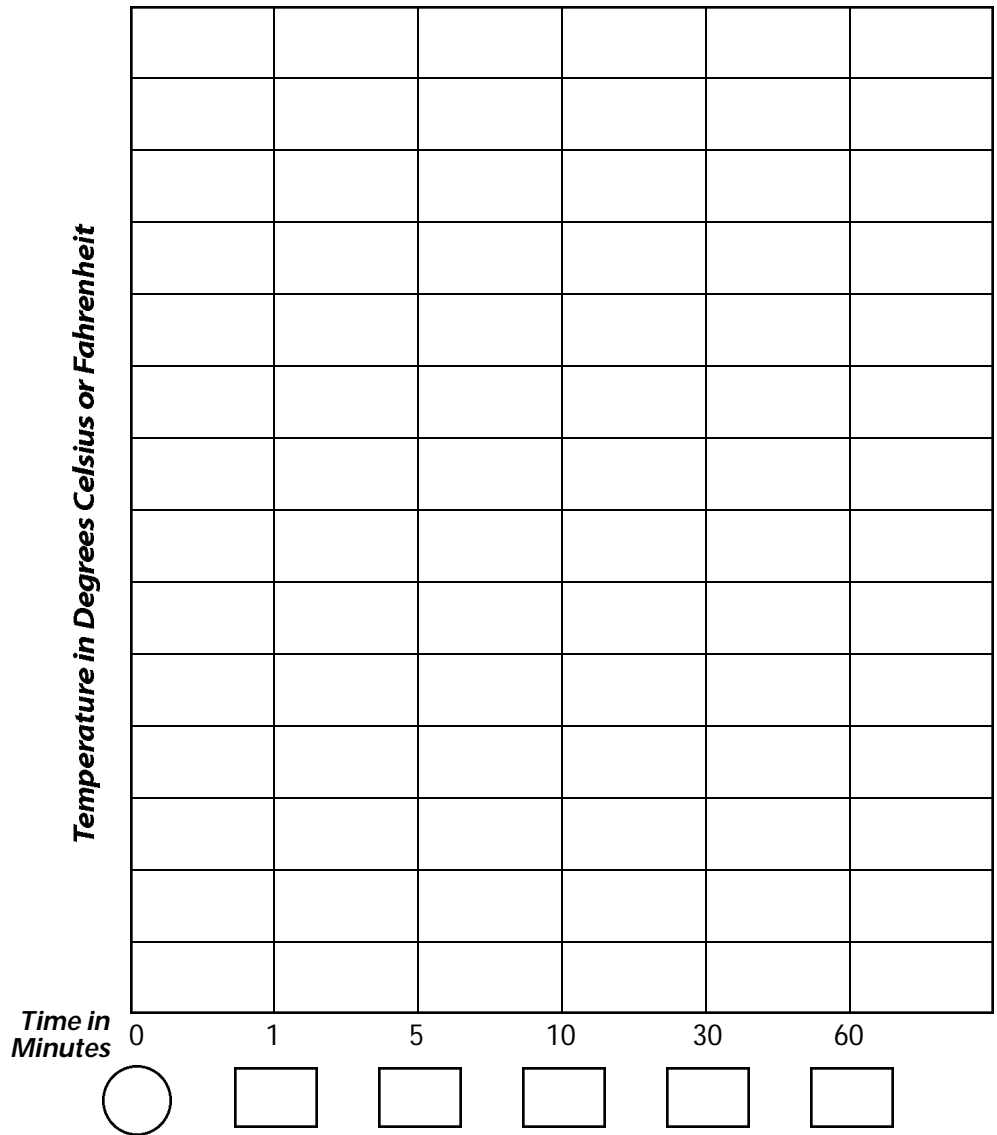

Final temperature - Starting temperature = Total temperature change

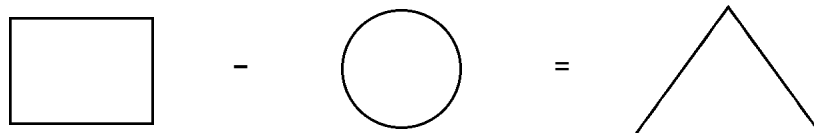

STUDENT ACTIVITY ONE LAB SHEET**How Does the Make-up of the Atmosphere Affect Temperature?**

Name _____

Answer the following questions:

1. What was the total temperature change in Tank 1?

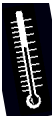

2. What was the total temperature change in Tank 2?



3. Which tank had the highest final temperature?



4. Connect the temperature marks on the graphs on the other pages of your Student Activity One Lab Sheets. Which tank heated up the quickest?



5. Explain why the two tanks heated up differently.



6. Explain how the experiment relates to what we are experiencing on Earth. Some words you might use in your answer are: atmosphere, greenhouse gases, pollution exhaust, carbon dioxide, and solar radiation.



7. Make a prediction about what life on Earth may be like in 200 years if temperatures continue to increase.



8. What do you think are some natural ways the Earth's climate system may counteract the warming?



ACTIVITY TWO

How Do Higher Temperatures Affect The Water Cycle?

This activity will show that an increase in temperature will speed up the water cycle. One outcome will be an increase in rainfall. A second outcome will be the increase in total evaporation of water and subsequent drought.

NOTE: This activity has two parts. The first part, Steps 1 and 2, compare Tank 1, a covered, unheated tank, with Tank 2, a covered, heated tank. In the second part, Step 3, the cover of Tank 1 is removed (and is now called Tank 3) and a lamp is added. Depending on the temperature of your classroom, you will need to run this lab observation for at least a couple of days so that the unheated Tank 1 in Step 1 of the experiment will have enough time to form condensation inside. As noted in Activity One, setting up two tanks at a time will provide a more dramatic comparison. If you have a third tank, you can run all three experiments simultaneously.

MATERIALS

- Tanks from Activity One
- Glass or plastic covers
- Tinted plastic wrap or transparency paper
- Clamp lamp with 60-watt bulb (If conducting all 3 simultaneously, 2 lamps are needed)
- Water
- Blue food coloring (optional)
- Pencils
- Crayons or colored pencils
- Student Activity Two lab sheets

PROCEDURE

Step 1

Add a little blue food coloring to a liter of water and pour in enough to cover the bottom of each tank (about 2 cm). Place a glass cover over each tank. Place a lamp and plastic wrap over Tank 2 (Tank 1 has no lamp). (*NOTE: Place the plastic wrap around the lamp bell, not under it. CAUTION: Material in direct contact with the bare bulb may catch fire. Explain to the students this is only being done to prevent the plastic wrap from catching on fire. In the "real" atmosphere, the sun's rays pass directly through the atmosphere.*) Draw a picture and record the initial temperature in each tank on the *Student Activity Two Lab Sheets* and turn on the light over Tank 2.

Step 2

After about 1 hour, have your students draw a picture of the changes they observe on the lab sheets. Be sure to record the starting temperatures of each tank. Repeat these observations in 24 hours and complete appropriate lab sheets. Discuss the differences in the rate of evaporation and precipitation in the tanks. What caused these differences? (The increased temperature made the water evaporate faster in Tank 2. Precipitation falls nearly continuously. In the real world, this may cause flooding and mud slides.)

Step 3

Now remove the glass cover of Tank 1 and place a lamp over it (we will now call this Tank 3). Have the students make predictions about what they think will happen. Write the answers on the lab sheet for Tank 3. Record the temperature and turn on the lamp. Record the changes in Tank 3 at 1 hour, 24 hours, and 48 hours.

Step 4

Complete lab sheets.

CONCLUSION

- Discuss the differences now seen between Tanks 2 and 3. What has happened to the water in Tank 3?
- Ask how the effect of increased heat in the tanks might relate to what we see happening to the climate of the real world.
- Discuss how the conditions observed would change the Earth. In the discussion include the effects of increased and decreased precipitation (including drought, salinity, mineralization, flooding, mudslides, increased vegetation in arid areas, increased ground water supply, increased wetlands habitats, etc.) and how they would influence the local environments.

EXTENSION

Add a couple of spoonfuls of salt to the water in Tank 1. Once the water has completely evaporated, the salty residue will provide the material for a discussion of how evaporation increases salinity and mineralization of land and water subjected to increased rates of evaporation.

STUDENT ACTIVITY TWO LAB SHEET
How Do Higher Temperatures Affect the Water Cycle (Tank 1)?

Name _____

TANK 1

Draw the interior of your tank before the experiment begins:

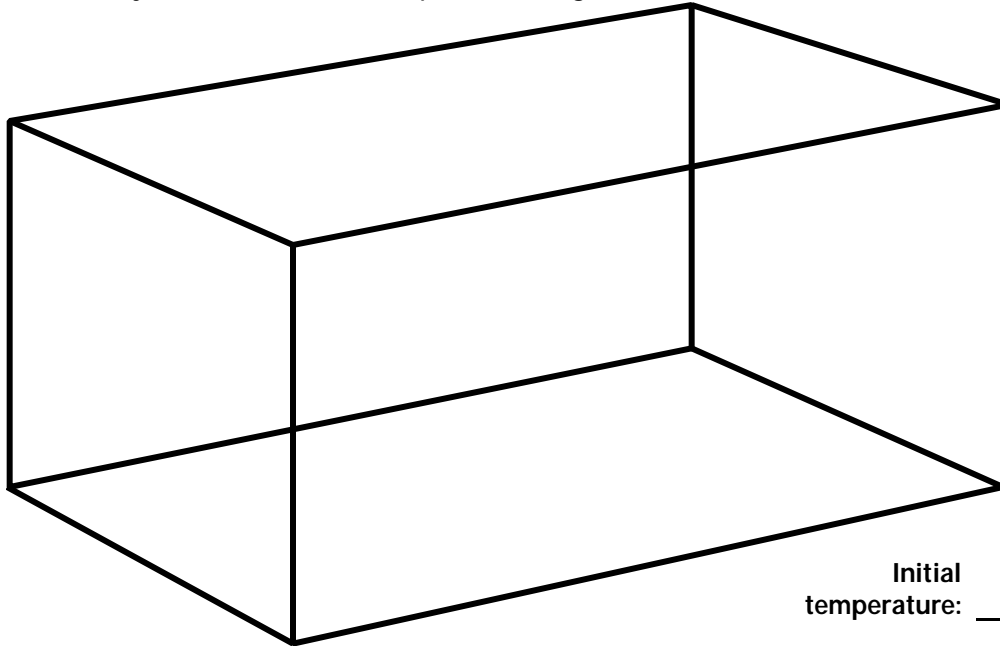

Initial temperature: _____

Draw the interior of your tank after 1 hour:

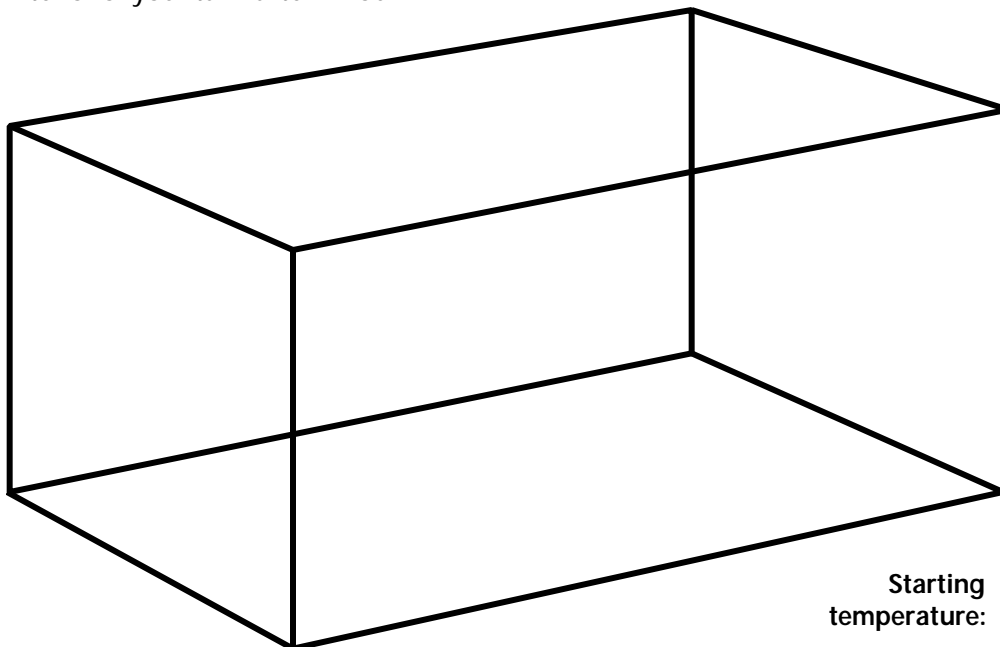

Starting temperature: ○

TANK 1 (cont.)

Draw the interior of your tank after 24 hours:

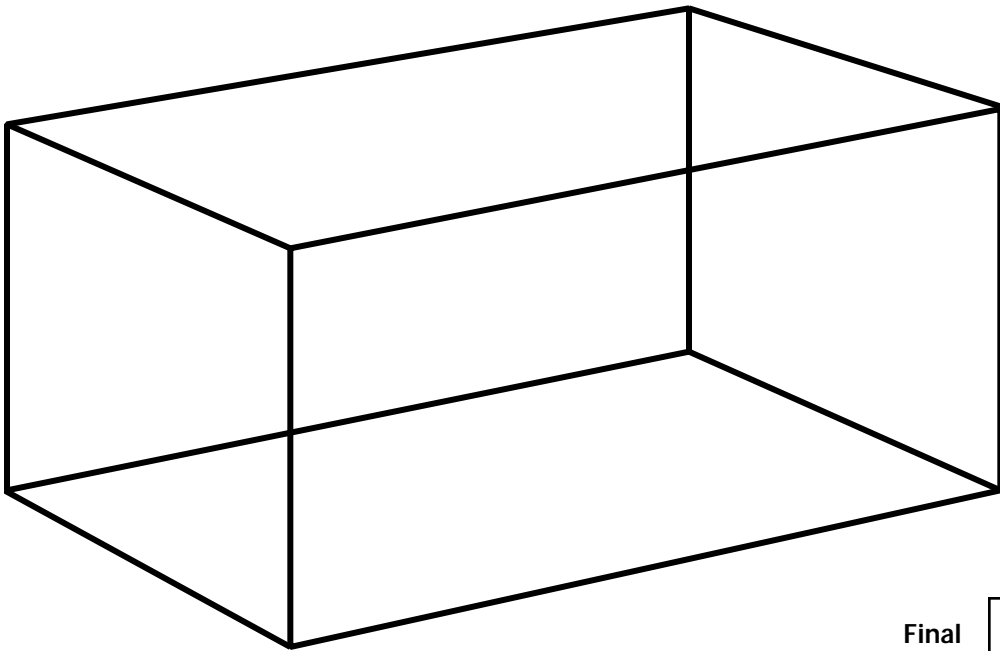

Final temperature:

TANK 1

Final temperature – Starting temperature = Total temperature change



-

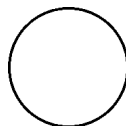

=

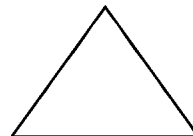

STUDENT ACTIVITY TWO LAB SHEET
How Do Higher Temperatures Affect the Water Cycle (Tank 2)?

Name _____

TANK 2

Draw the interior of your tank before the experiment begins:

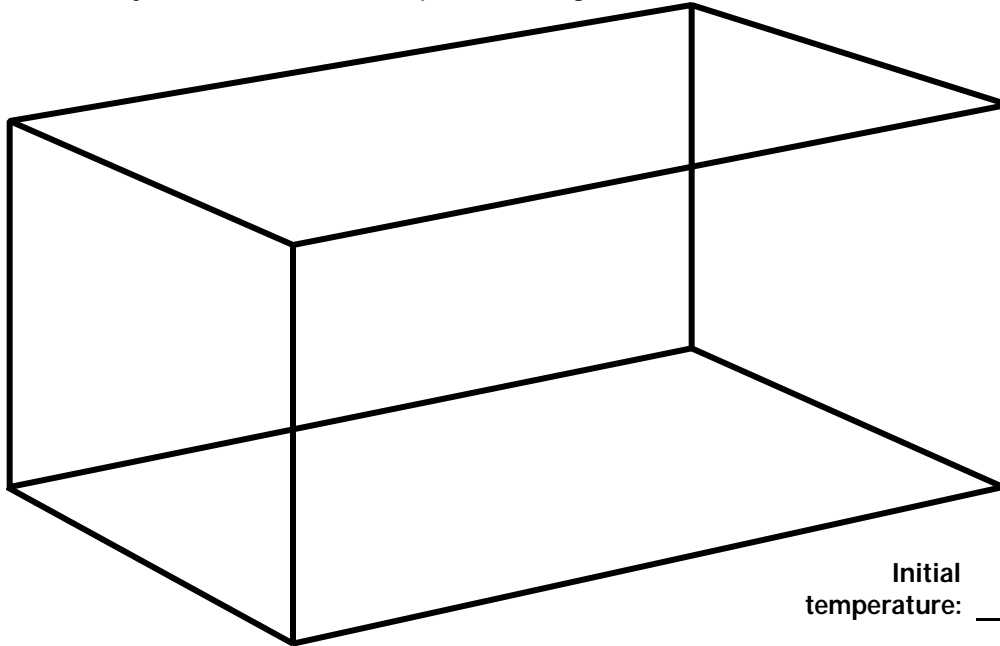

Initial temperature: _____

Draw the interior of your tank after 1 hour:

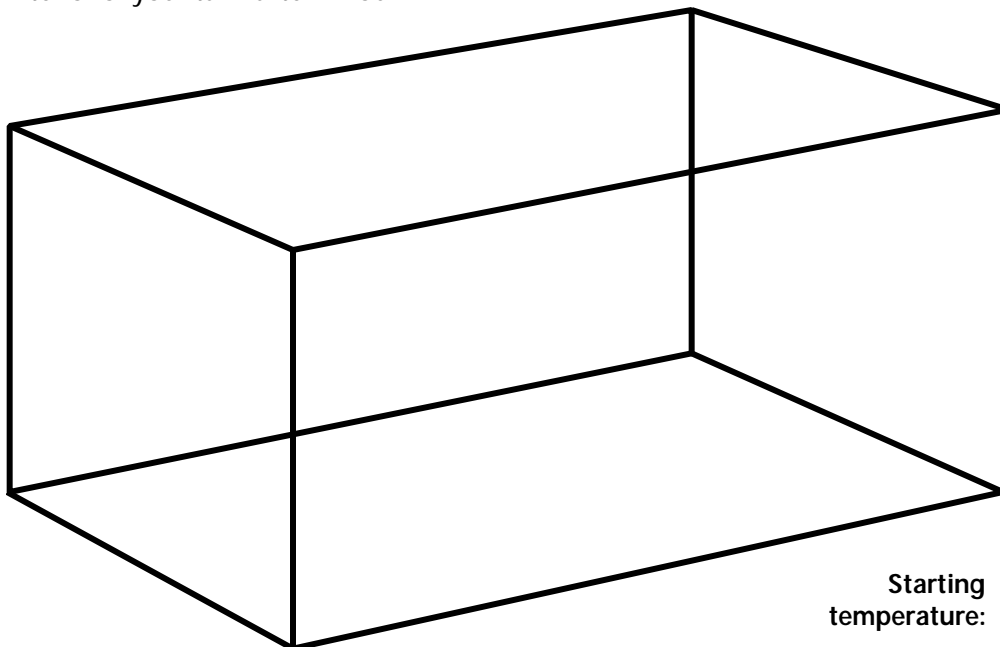

Starting temperature: ○

TANK 2 (cont.)

Draw the interior of your tank after 24 hours:

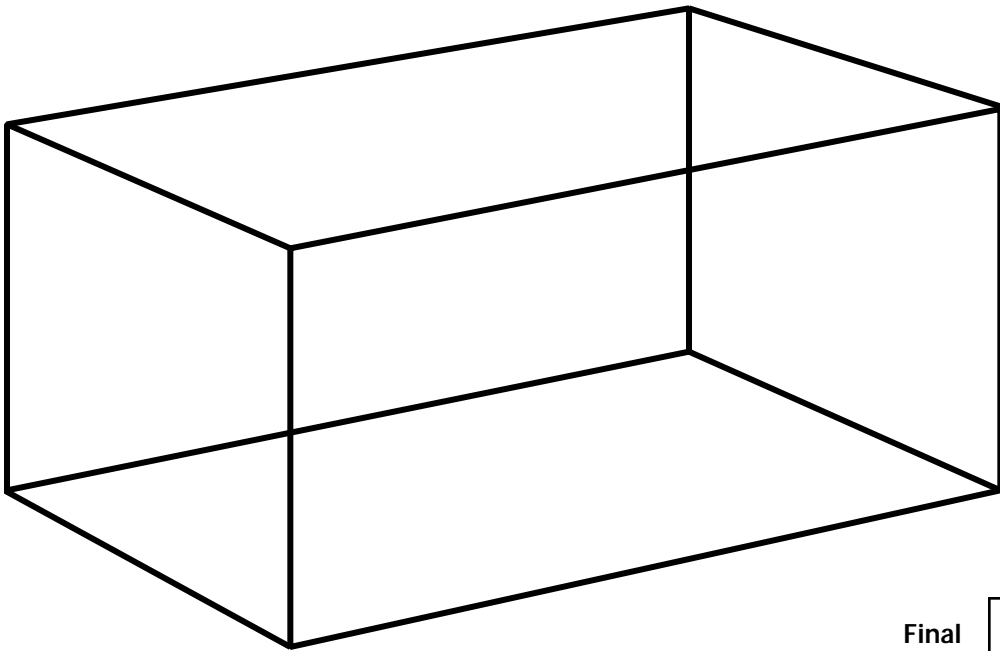

Final temperature:

TANK 2

Final temperature – Starting temperature = Total temperature change

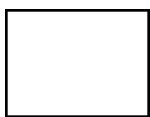

-

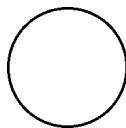

=



STUDENT ACTIVITY TWO LAB SHEET

How Do Higher Temperatures Affect the Water Cycle (Tank 3)?

Name _____

What do you think will happen to Tank 3 when a lamp is placed over it?



TANK 3

Draw the interior of your tank before the experiment begins:

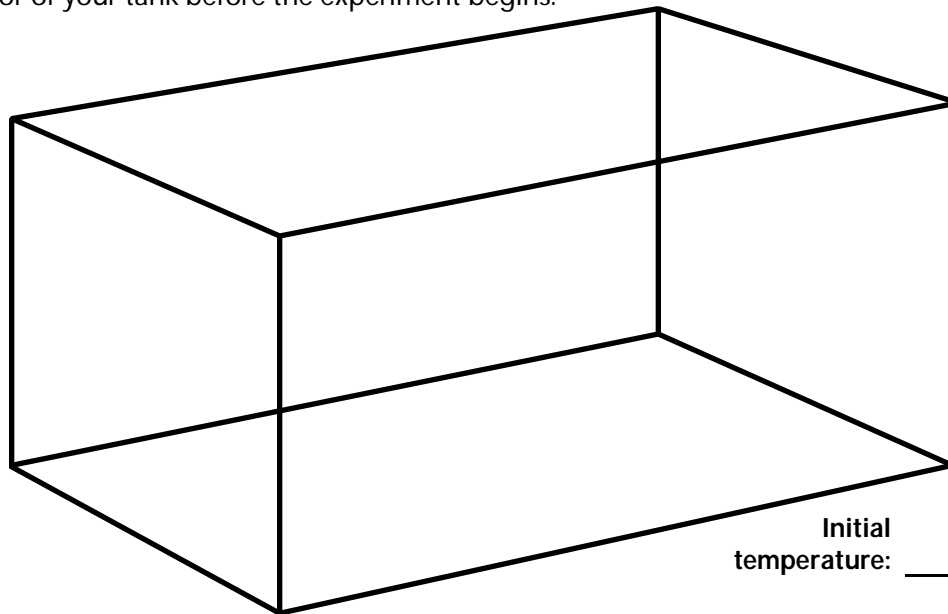

Initial temperature: _____

Draw the interior of your tank after 1 hour:

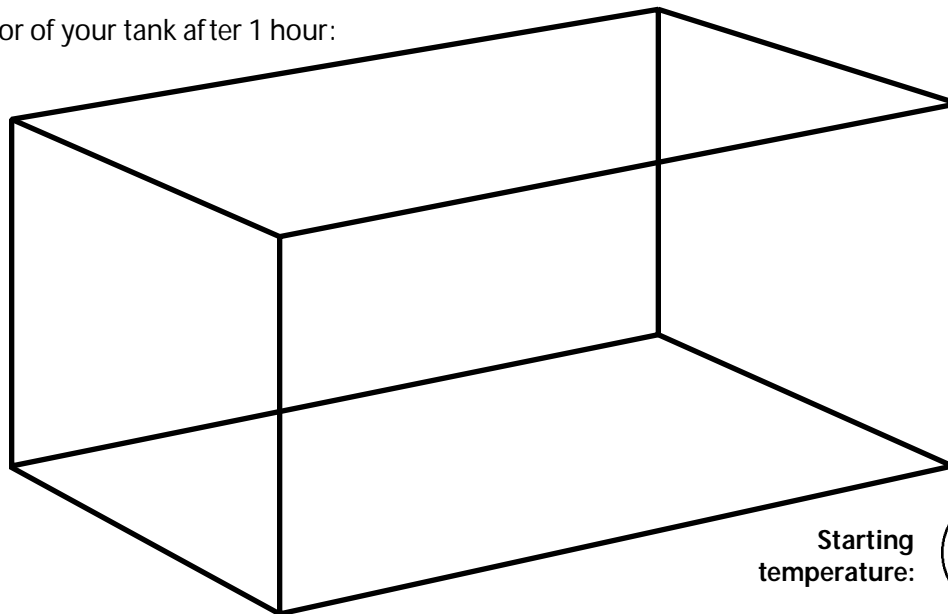

Starting temperature: ○

TANK 3 (cont.)

Draw the interior of your tank after 24 hours:

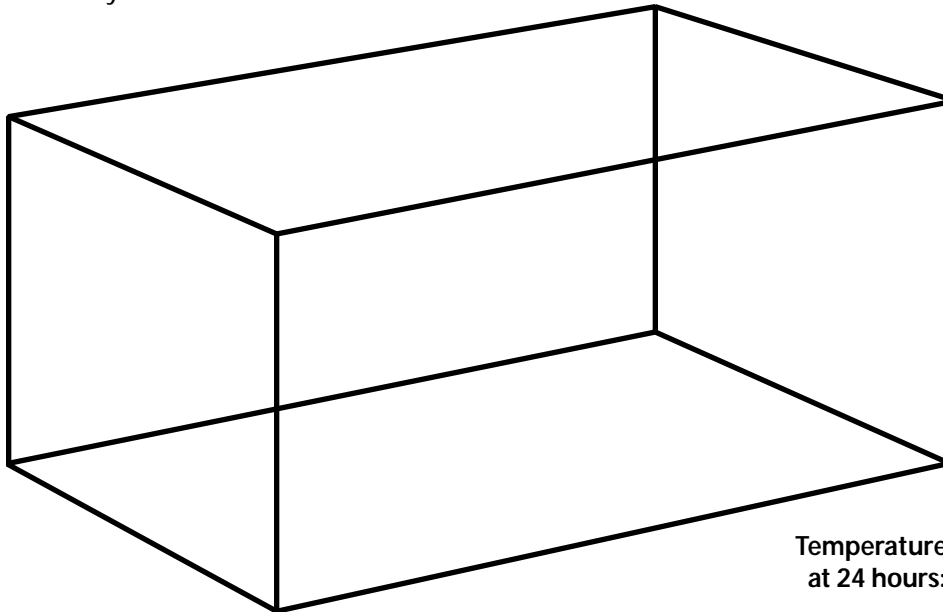

Temperature at 24 hours:

Draw the interior of your tank after 48 hours:

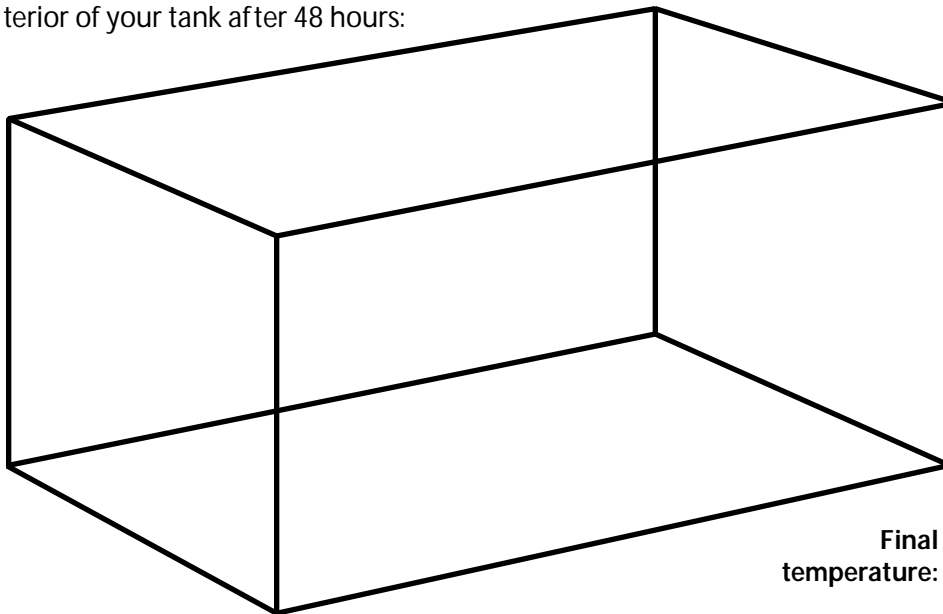

Final temperature:

TANK 3

Final temperature - Starting temperature = Total temperature change



-

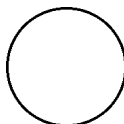

=

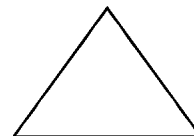

STUDENT ACTIVITY TWO LAB SHEET

How Do Higher Temperatures Affect the Water Cycle?

Name _____

Answer the following questions:

1. Describe the differences you observed between Tanks 1 and 2 after 24 hours.



2. Describe the differences in evaporation and precipitation between Tanks 1 and 2.



3. How would a large increase in rainfall affect your region? What impacts might result?



4. Describe what you saw in Tank 3 after 24 and 48 hours.



5. What happened in Tank 3?



6. What caused the differences between Tanks 1,2 and 3 in this experiment?



7. What do we call this condition when it happens on Earth?



ACTIVITY THREE

What Will Happen If Climate Variability & Change Cause Glacier & Polar Ice Cap Melting?

This activity will show how increased temperatures will hasten the melting of ice in the environment, contributing to a rise in sea level and subsequent flooding of coastal areas.

MATERIALS

- Tanks from Activity One
- Glass or plastic covers
- Two clamp lamps with 60-watt bulbs
- Tinted plastic wrap or transparency paper
- Water
- Blue food coloring (optional)
- “Icebergs” and “glaciers” (freeze water in paper cups or milk cartons; peel off paper)
- Rulers
- Pencils
- Crayons
- Grease pencil or marker (optional)
- Graph paper
- Student Activity Three lab sheets

PROCEDURE

Step 1

Set up Tank 1 and Tank 2 as in Activity One. Add blue food coloring to the water (optional) and carefully pour into the tank. Take a baseline temperature. Measure the water level in the tank. (You may wish to tape a ruler to the front of the tank and mark the water level on the tank glass with a grease pencil or marker.) Record data on the *Student Activity Three Lab Sheets* for *Tanks 1 and 2*.

Step 2

Explain the difference between glaciers and icebergs to the students. Then place one or more “icebergs” and “glaciers” in your tanks (see Figure 3). Note the rise in the water level with the introduction of the ice. Draw a diagram of the tank and measure and record the new temperature and water height on the *Student Activity Three Lab Sheets* for *Tanks 1 and 2*.

Figure 3. Tank Set-up with “Icebergs” and “Glaciers”

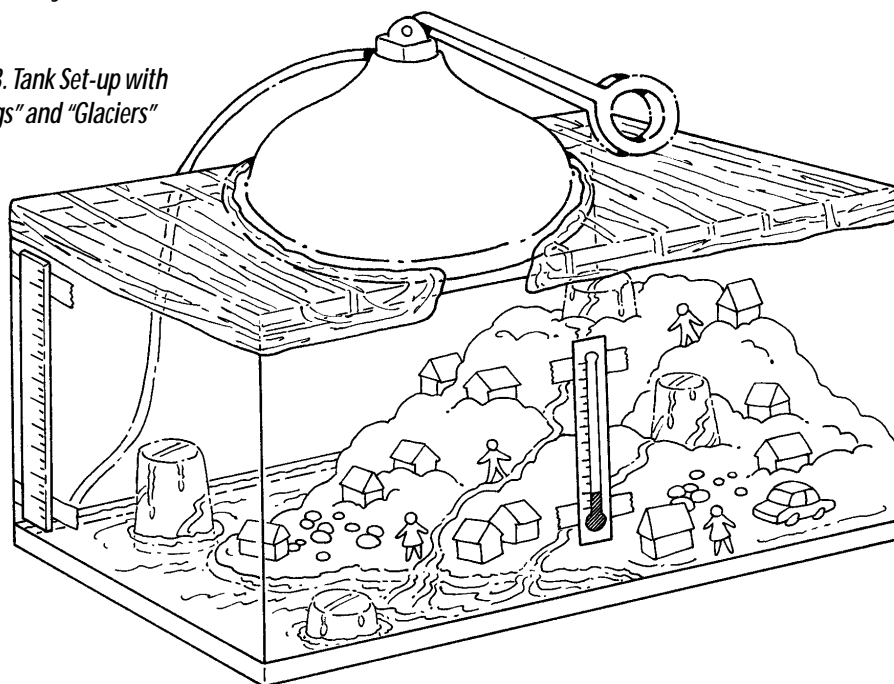

Step 3

Place a lamp over Tank 1. Place a glass cover, plastic wrap, and a lamp over Tank 2. (*NOTE: Place the plastic wrap material around the lamp bell, not under it. CAUTION: Material in direct contact with the bare bulb may catch fire. Explain to the students this is only being done to prevent the plastic wrap from catching on fire. In the “real” atmosphere, the sun’s rays pass directly through the atmosphere.*) Record the temperature and water level changes in the tanks at 1,5,10,30, and 60-minute intervals on the lab sheets.

Step 4

Complete lab sheets.

CONCLUSION

- Discuss the differences in melt rates and water rise in Tanks 1 and 2;
- Ask what happened to the homes and buildings on the shoreline;
- Ask why climate variability and change on Earth might affect the coastline development in the United States and other places;
- Discuss how knowing about changes in climate in advance might affect settlement patterns and building planning in coastal areas.

EXTENSIONS

1. Research and discuss how and where glaciers form. How would these conditions and regions be affected by climate variability and change?
2. Have the students compare the glaciers with the icebergs from their activity. What makes them different? Where do icebergs come from? Ask the students to predict what would happen to an iceberg as it floats in the ocean.

STUDENT ACTIVITY THREE LAB SHEET

What Will Happen if Climate Variability & Change Cause Glacier & Polar Ice Cap Melting (Tank 1)?

Name _____

TANK 1

1. Draw the interior of Tank 1 after the glaciers and icebergs were added:

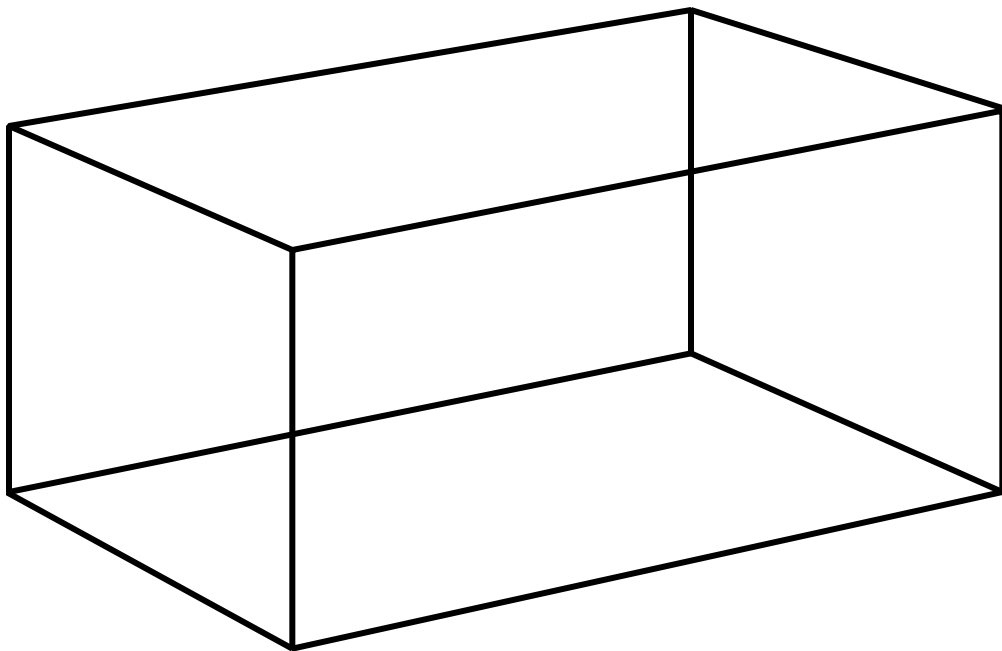

2. MEASUREMENTS

TIME	TEMPERATURE	WATER HEIGHT
Before ice is added		
After ice is added		
1 minute		
5 minutes		
10 minutes		
30 minutes		
60 minutes		

3. Draw a diagram of Tank 1 below after 60 minutes.

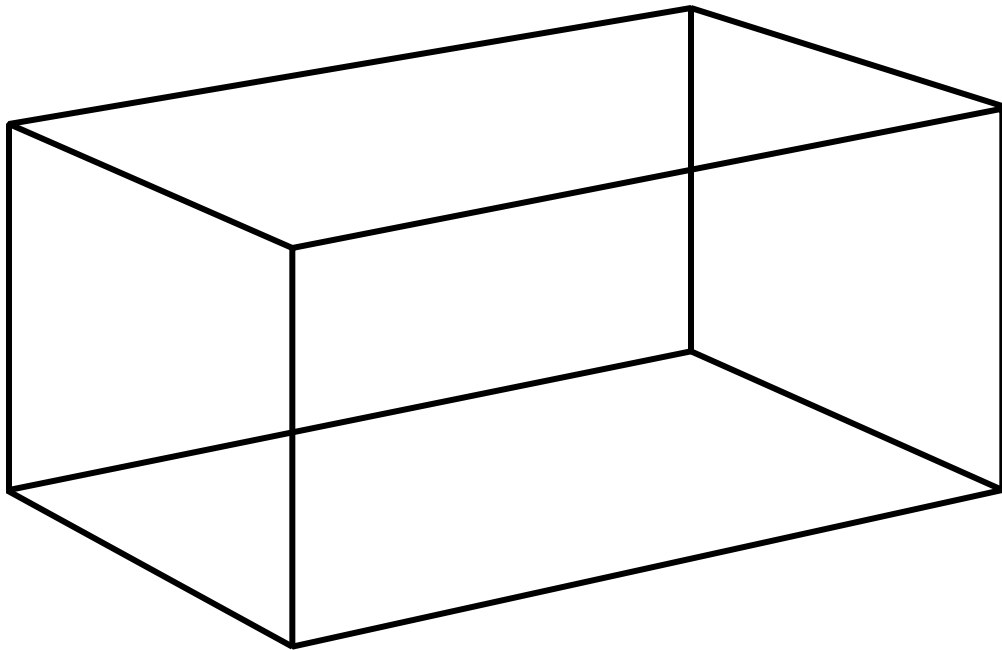

4. Using graph paper, make a graph of both temperature and wave height for Tank 1.

STUDENT ACTIVITY THREE LAB SHEET

What Will Happen if Climate Variability & Change Cause Glacier & Polar Ice Cap Melting (Tank 2)?

Name _____

TANK 2

1. Draw the interior of Tank 2 after the glaciers and icebergs were added:

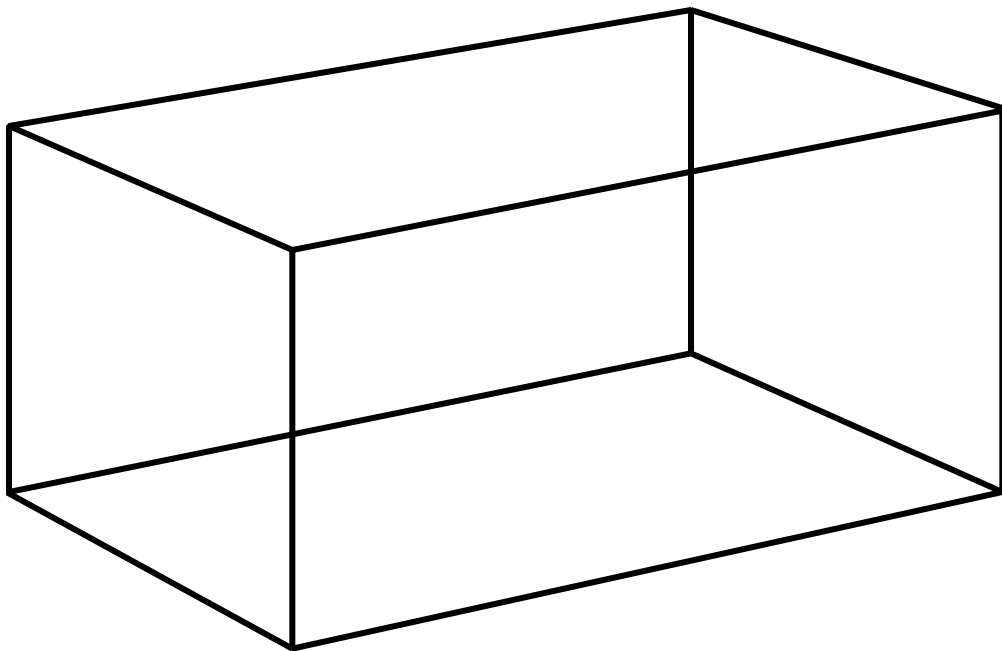

2. MEASUREMENTS

TIME	TEMPERATURE	WATER HEIGHT
Before ice is added		
After ice is added		
1 minute		
5 minutes		
10 minutes		
30 minutes		
60 minutes		

3. Draw a diagram of Tank 2 below after 60 minutes.

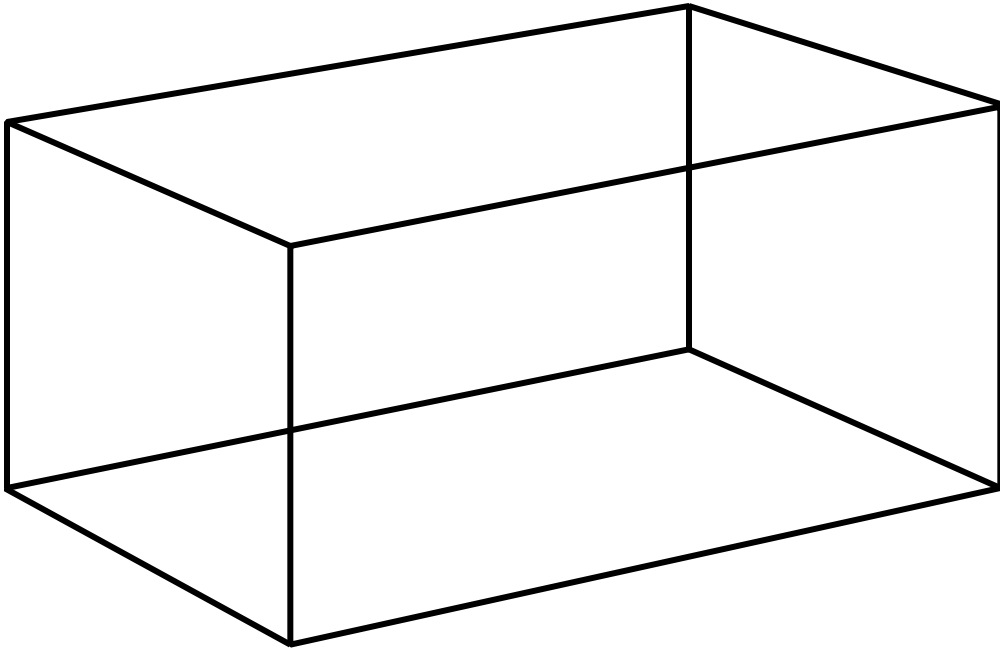

4. Using graph paper, make a graph of both temperature and wave height for Tank 2.

STUDENT ACTIVITY THREE LAB SHEET

What Will Happen if Climate Variability & Change Cause Glacier & Polar Ice Cap Melting?

Name _____

Answer the following questions:



1. What was the total temperature change in Tank 1?

2. What was the total temperature change in Tank 2?



3. Which tank had the highest final temperature?



4. Connect the temperature marks on the graphs you made. Which tank heated up the quickest?



5. Explain why the tanks heated up differently.



6. What differences did you observe between Tanks 1 and 2? Did the ice melt at different rates? Describe what you saw.



7. What happened to the coastline of your land? Did the rising water affect any buildings?



8. What kinds of problems might this situation cause in the real world?



-
9. Sea levels around the world ARE rising as a result of climate variability and change. What information might we need to know to plan for a future of rising sea levels on Earth?



-
10. Given all that you have learned from the experiments in Activities One, Two and Three, what are some serious challenges we may face as a result of climate variability and change?



-
11. What actions can we take now to counteract our impacts on climate variability and change?



Appendix A

Bibliography

■ CURRICULUM MATERIALS

Lawrence Hall of Science. *Great Explorations in Math and Science (GEMS): Hot Water and Warm Homes from Sunlight*. Berkeley, CA. 1990

Ranger Rick's Nature Scope. *Pollution: Problems & Solutions*. National Wildlife Federation. Washington, DC. 1990.

■ BOOKS

Allaby, Michael. 1998. *Dangerous Weather: Drought*. Facts on File, Inc. New York, NY.

Costa-Pau, Rosa. 1994. *Keeping the Air Clean*. Chelsea House Publishers. New York, NY.

Dolan, Edward F. 1991. *Our Poisoned Sky*. Cobblehill Books. New York, NY.

Johnson, Rebecca L. 1990. *The Greenhouse Effect: Life on a Warmer Planet*. Lerner Publications Company. Minneapolis, MN.

Johnson, Rebecca L. 1993. *Investigating the Ozone Hole*. Lerner Publications Company. Minneapolis, MN.

Kahl, Jonathan D.W. 1998. *Hazy Skies: Weather and the Environment*. Lerner Publications Company. Minneapolis, MN.

Miller, Christina G. and Louise A. Berry. 1996. *Air Alert: Rescuing the Earth's Atmosphere*. Atheneum Books for Young Readers. New York, NY.

Pringle, Laurence. *Global Warming: Assessing the Greenhouse Threat*. Arcade Publishing, Inc. New York, NY. 1990.

Pringle, Laurence. *Vanishing Ozone: Protecting Earth from Ultraviolet Radiation*. Morrow Junior Books. New York, NY. 1995.

Savan, Beth. *Earthwatch: Earthcycles and Ecosystems*. Addison Wesley Publishing Co. 1991.

Stille, Darlene R. *A New True Book: The Greenhouse Effect*. Childrens Press. Chicago, IL. 1990

Stille, Darlene R. *A New True Book: Air Pollution*. Childrens Press. Chicago, IL. 1990.

Stille, Darlene R. *A New True Book: The Ozone Hole*. Childrens Press. Chicago, IL. 1991.

Tordjman, Nathalie. *Climates Past, Present and Future*. Childrens Press/Baron's Educational Publishing. New York, NY. 1988.

VanCleave, Janice. *A+ Projects in Chemistry*. John Wiley and Sons, Inc. New York, NY. 1993.

VanCleave, Janice. *Ecology for Every Kid*. John Wiley and Sons, Inc. New York, NY. 1996.

■ INTERNET RESOURCES

NASA Sites

Earth Science Enterprise
<http://www.earth.nasa.gov>

Spacelink—educationsite
<http://spacelink.msfc.nasa.gov/index.html>

NASA's Observatorium: Planet Earth
<http://observe.ivv.nasa.gov/>

Exploring the Environment: Classroom of the Future
<http://www.cotf.edu/ete>

GSFC Earth Space Science Education Project
<http://hpcc-k12.gsfc.nasa.gov/gessep/>

Other Sites

NOAA Information on Global Warming and Climate Change
<http://www.esdim.noaa.gov/>

Lycos Webguide to Global Warming, Climate Change, Environmental Effects Sites
http://www_uk.lycos.com/webguides/technology/m_warm2.html

Teaching Resources for Education in Earth Science
<http://earthview.sdsu.edu>

CoVis Weather Visualization Tools
<http://covis.atmos.uiuc.edu/>
Click on UIUC—CoVis Geosciences Web Server
Click on Visualization Tools

1-Week Curriculum on Global Warming for 6th Graders
<http://www.ci.chula-vista.ca.us/glbwarm.htm>

The Weather Classroom
<http://www.weather.com/education>

Newton's Apple Television and Video Program Experiments—Greenhouse Gases
<http://www.ktca.org/newtons/15/greenhouse.html>

Assessment Rubric & Answer Keys

ASSESSMENT RUBRIC

As children in the primary grades grow and learn, their thinking skills expand and grow in predictable ways. But these developmental milestones are achieved along a continuum. It is impossible to say that “every first grader will be able to...” when the topic is one that requires comparing more than one variable or needs abstract reasoning skills to grasp. Global climate change is such a topic. To assess students fairly, it must be understood that some students will grasp these complicated lessons with relative ease, while others will not be developmentally ready in spite of teaching efforts or techniques.

Teachers in the primary grades who regularly use developmentally-based learning activities understand this assessment piece. They know that the less concrete the learning goals of a lesson, the more difficult the activity will be to assess. For example, it is much more difficult to assess a student’s understanding of the relevance of other living things to their own lives, than to assess whether a student can use a thermometer to measure the temperature in a glass of ice water. To quote George E. Hein and Sabra Price from their book *Active Assessment for Active Science*, “Attitudes and global concepts...are very hard to assess, and are often best approached through observation, if they are assessed at all.”

The checklist on pages 26 and 27 will help assess your students’ understanding of these lessons over a developmental continuum. Children in Kindergarten and Grade 1 who can perform the first several tasks at the beginning of each activity checklist demonstrate good proficiency at their age level. Children in Grade 4 should be able to perform almost all of the items on each checklist to show equal proficiency. For Kindergarten and Grades 1 and 2, teachers should expect to find a range of proficiency within each grade, much of which will be determined by developmental readiness. By Grade 3, students’ abstract reasoning and better comparison skills are much more developed and expectations for students rise.

Please use this checklist as a guide, not a rule. Observe, listen, question, and expand upon what your students learn from these activities. Be sure to ask for illustrations as well as written and oral explanations in your assessment. Push your students to think beyond their normal frame of reference.

The checklist is keyed for these skills:

Observing, Explaining, Predicting, Measuring, and Applying New Concepts.

ASSESSMENT CHECKLISTS Global Warming: Activities One–Three

- O = Observing
- E = Explaining
- P = Predicting
- M = Measuring
- A = Applying New Concepts

Activity One**HOW DOES THE MAKE-UP OF THE ATMOSPHERE AFFECT TEMPERATURE?**

- O Identifies and describes the elements within the tank—land, water, lid, lamp, and thermometer. (1–4)
- O Observes and describes the function of the lamp as a heat source. (1–4)
- O Observes the rising temperature reading on the thermometer when heat is added to the tank. (1–4)
- O When asked about the “empty space” in the tank, describes that it is filled with air even though it is not observable. (1–4)
- O Identifies the tank lid and the insulating material on the lid as part of the sky or atmosphere. (1–4)
- E Explains that a thermometer measures temperature. (1–4)
- E Explains that the Sun heats the Earth. (1–4)
- E Explains that the Earth is surrounded by air. Can draw a picture to illustrate. (2–4)
- E Explains that the atmosphere sometimes has clouds, air pollution, and other components that make it appear cloudy or hazy. (2–4)
- E Explains that some sources of pollution are man-made. (2–4)
- E Explains that some sources of air pollution are natural. (3–4)
- P Predicts a rise in temperature when the lamp is turned on. (1–4)
- P Predicts that the tank covered with the plastic wrap will get warmer. (2–4)
- P Predicts that temperatures will be higher in a tank covered with plastic wrap. (3–4)
- P Predicts that a denser atmosphere will make the Earth warmer over time. (3–4)
- P Predicts that the earth will grow warmer and warmer if the emission of greenhouse gases is not limited. (4)
- M Reads and records the thermometer reading. (2–4)
- M Can calculate the total change of temperature over time. (2–4)
- M Reads the thermometer and keeps track of elapsed time for temperature recordation. (3–4)
- M Can graph the change of temperature over time. (3–4)
- A Explains how the tank system is like the Earth and the lamp is like the sun. (K–4)
- A Explains that insulation keeps things warmer. (1–4)
- A Explains that the “blanket” of atmosphere keeps things warm. Can draw a picture to illustrate this effect. (3–4)
- A Describes (using the tank as an example) what global warming is. Can draw a picture to illustrate global warming. (3–4)

Activity Two

HOW DO HIGHER TEMPERATURES AFFECT THE WATER CYCLE?

- O Observes condensation inside the tank. (1–4)
- O Observes that there is more condensation in the heated tank than the unheated tank. (1–4)
- O Observes and describes that condensation is not forming on the lidless tank. (2–4)
- O Observes and describes that the water level in the lidless tank is decreasing. (2–4)
- E Explains that the condensation is made of water. (1–4)
- E Explains the water cycle in his or her own words. Can draw a picture to illustrate the water cycle. (2–4)
- E Explains that the water in the tank evaporated and escaped the tank. (2–4)
- E Explains the relationship between the acceleration of the water cycle to the rapid disappearance of the water in the tank. (3–4)
- P Predicts that there will be more condensation in a tank with more heat. (2–4)
- P Predicts that the water level will decrease in a lidless tank. (3–4)
- P Predicts flooding as a result of increased rainfall. (4)
- P Predicts an increased possibility of drought when water evaporates more quickly than it is replaced by rainfall. (4)
- M Measures the water level in the tank with a ruler and records it. (2–4)
- A Explains the relationship of the acceleration of the water cycle to an increase of rainfall on Earth. (3–4)
- A Explains how global warming may cause drought in some places. (4)

Activity Three

WHAT WILL HAPPEN IF CLIMATE VARIABILITY & CHANGE CAUSE GLACIER & POLAR ICE CAP MELTING?

- O Observes and describes that ice placed in the tank is melting. (1–4)
- O Observes and describes that the water level in the tank with melting ice is rising. (1–4)
- E Explains that the higher temperature makes the ice melt faster. (1–4)
- P Predicts that the ice placed in the tank will melt. (1–4)
- P Predicts that the water level in the tank will rise. (2–4)
- P Predicts that the sea level will rise as a result of increasing temperature on Earth. (4)
- P Predicts the coastal effects of a change of sea level. (4)
- M Measures the water level in the tank with a ruler and records it. (2–4)
- A Explains the relationship of the experiment in the tank to the Earth. (2–4)

ANSWER KEYS Lab Sheets: Activities One–Three

Activity One Lab Sheet**HOW DOES THE MAKE-UP OF THE ATMOSPHERE AFFECT TEMPERATURE?**

Students' answers should be in their own words and in complete sentences.

1. Calculate temperature change from laboratory readings.
2. Calculate temperature change from laboratory readings.
3. Tank 2 had the highest final temperature.
4. Tank 2 heated up most quickly.
5. The two tanks heated up differently because Tank 1 did not have a lid and plastic wrap, while Tank 2 did. The lid and plastic wrap acted as an insulator, preventing the heat from escaping from Tank 2.
6. The experiment relates to what we are experiencing on Earth because it demonstrates how the atmosphere is changing due to an increase in greenhouse gases. These gases act as an insulator (as did the lid and batting) that traps solar radiation. The solar radiation is converted to heat, causing temperatures on Earth to rise. The amounts of greenhouse gases such as carbon dioxide are increasing in the atmosphere in part due to pollution exhaust from human activity.
7. Any answer should be accepted as long as it incorporates the concept of increased global temperatures and the effects it will have on the Earth's climates.

Activity Two Lab Sheet**HOW DO HIGHER TEMPERATURES AFFECT THE WATER CYCLE?**

Students' answers should be in their own words and in complete sentences.

1. After 24 hours, the temperature in Tank 2 is higher than in Tank 1. This caused the water in Tank 2 to evaporate and form precipitation more quickly.
2. Water evaporated faster in Tank 2 than in Tank 1, due to the heat source. This caused almost continual precipitation in Tank 2. (This is a general answer. Individual attempts may vary, so answers should be adjusted accordingly.)
3. A large increase in rainfall could cause increased local flooding and erosion, including mudslides. Student answers can be varied and should include positive and/or negative effects on humans, plants, animals, and the Earth's surface.
4. After 24 and 48 hours the water in Tank 3 evaporates without forming precipitation.
5. In Tank 3 there was no lid to "trap" the evaporated water. The water escaped from the tank.
6. The differences among the three tanks are that the water in Tank 1 evaporated slowly because the temperatures remained cooler. The same occurred in Tank 2, only the heat from the lamp caused the evaporation and precipitation rate to speed up. Tank 3 also had a fast evaporation rate, but because there was no lid, the water escaped into the atmosphere. No precipitation formed.
7. This is called the greenhouse effect.

Activity Three Lab Sheet

WHAT WILL HAPPEN IF CLIMATE VARIABILITY & CHANGE CAUSE GLACIER & POLAR ICE CAP MELTING?

Students' answers should be in their own words and in complete sentences.

1. Calculate temperature change from laboratory readings.
2. Calculate temperature change from laboratory readings.
3. Tank 2 had the highest final temperature.
4. Tank 2 heated up more quickly.
5. The two tanks heated up differently because Tank 2 had a cover and plastic wrap that helped trap the heat in the tank.
6. The difference is that the cover and plastic wrap on Tank 2 retained the heat, causing the ice to melt faster.
7. The coastline flooded. The effect on buildings will be unique to your set-up. Answers will vary.
8. This might cause the destruction of buildings, the loss of property, large population relocations, or any other answer that applies observations from the activity.
9. We need to know how high the sea level will rise, how this rise will affect coastlines, and alternate locations for populations.
10. Some serious challenges could be a significant increase in worldwide temperatures that can affect evaporation and precipitation rates. Areas where precipitation will increase can expect to see changes to the Earth's surface (such as mudslides) due to increased erosion, and a possible increase in vegetation. Other areas, where precipitation will decrease, can expect to have droughts or decreased flooding. Lastly, we might face a rise in sea level due to the melting of glaciers. The answers given can address both positive and negative issues.
11. We can reduce the release of greenhouse gases by controlling human pollution, planting more trees, stopping deforestation, reducing fossil fuel burning (which adds aerosols to the atmosphere), etc.

Appendix C

National Education Standards

This activity responds to the following National Education Standards:

STANDARDS FOR THE ENGLISH LANGUAGE ARTS

Standard 3: Students apply a wide range of strategies to comprehend, interpret, evaluate, and appreciate texts. They draw on their prior experience, their interactions with other readers and writers, their knowledge of word meaning and of other texts, their word identification strategies, and their understanding of textual features (e.g., sound-letter correspondence, sentence structure, context, graphics).

Standard 4: Students adjust their use of spoken, written, and visual language (e.g., conventions, style, vocabulary) to communicate effectively with a variety of audiences and for different purposes.

Standard 5: Students employ a wide range of strategies as they write and use different writing process elements appropriately to communicate with different audiences for a variety of purposes.

Standard 7: Students conduct research on issues and interests by generating ideas and questions, and by posing problems. They gather, evaluate, and synthesize data from a variety of sources (e.g., print and nonprint texts, artifacts, people) to communicate their discoveries in ways that suit their purpose and audience.

Standard 8: Students use a variety of technological and informational resources (e.g., libraries, databases, computer networks, video) to gather and synthesize information and to create and communicate knowledge.

Standard 12: Students use spoken, written, and visual language to accomplish their own purposes (e.g., for learning, enjoyment, persuasion, and the exchange of information).

National Council of Teachers of English and International Reading Association. 1996. Standards for

the English Language Arts p.24–46. Urbana, Illinois and Newark, Delaware: National Council of Teachers of English and International Reading Association.

NATIONAL GEOGRAPHY STANDARDS GEOGRAPHY FOR LIFE (K–4)

Geography Standard 4: *Places and Regions.* The physical and human characteristics of places.

Geography Standard 7: *Physical Systems.* The physical processes that shape the patterns of the Earth's surface.

Geography Standard 12: *Human Systems.* The processes, patterns, and functions of human settlement.

Geography Standard 15: *Environment and Society.* How physical systems affect human systems.

American Geographical Society, Association of American Geographers, National Council for Geographic Education, and National Geographic Society. 1994. Geography for Life National Geography Standards p. 105–141. Washington, DC: National Geographic Research and Exploration.

CURRICULUM AND EVALUATION STANDARDS FOR SCHOOL MATHEMATICS

CURRICULUM STANDARDS: K–4

Standard 1: Mathematics as problem solving.

Standard 2: Mathematics as communication.

Standard 3: Mathematics as reasoning.

Standard 4: Mathematical connections.

Standard 6: Number sense and numeration

Standard 7: Computation and estimation

Standard 10: Measurement

Standard 11: Statistics and probability

National Council of Teachers of Mathematics. 1989. Curriculum and Evaluation Standards for School Mathematics p. 13–62. Reston, VA: The National Council of Teachers of Mathematics, Inc.

NATIONAL SCIENCE EDUCATION STANDARDS

CONTENT STANDARD: K–12

Unifying Concepts and Processes

Standard: As a result of activities in grades K–12, all students should develop understanding and abilities aligned with the following concepts and processes:

- Systems, orders, and organization
- Evidence, models, and explanation
- Consistency, change, and measure

National Research Council. 1996. National Science Education Standards p. 115–119. Washington, DC: National Academy Press.

CONTENT STANDARDS: K–4

Science as Inquiry

Content Standard A: As a result of activities in grades K–4, all students should develop:

- Abilities necessary to do scientific inquiry
- Understandings about scientific inquiry

Physical Science

Content Standard B: As a result of activities in grades K–4, all students should develop an understanding of:

- Properties of objects and materials

Life Science

Content Standard C: As a result of activities in grades K–4, all students should develop an understanding of:

- Organisms and environments

Science and Technology

Content Standard E: As a result of activities in grades K–4, all students should develop:

- Abilities of technological design
- Understandings about science and technology
- Abilities to distinguish between natural objects and objects made by humans

Science in Personal and Social Perspective

Content Standard F: As a result of activities in grades K–4, all students should develop understanding of:

- Personal health
- Types of resources
- Changes in environments

National Research Council. 1996. National Science Education Standards p. 173–207. Washington, DC: National Academy Press.

CURRICULUM STANDARDS FOR SOCIAL STUDIES

Strand 3: People, Places, & Environments. Social Studies programs should include experiences that provide for the study of people, places, and environments.

Strand 8: Science, Technology, & Society. Social Studies programs should include experiences that provide for the study of relationships among science, technology, and society.

Strand 9: Global Connections. Social Studies programs should include experiences that provide for the study of global connections and interdependence.

National Council for the Social Studies. 1994. Expectations of Excellence Curriculum Standards for the Social Studies p. 21–30. Washington, DC: National Council for the Social Studies.

Appendix D

Preliminary Experiments

USING A THERMOMETER

- Observe how a thermometer works under a lamp and in ice water.
- Practice reading and recording the degrees.
- Take temperatures in a number of settings.
- Take temperature readings over time intervals.

AIR IS THERE

- Use a shoe box with a hole in the end or an empty paper lunch sack to “squirt” air in your face.
- Build a balance scale with pins and drinking straws to measure which is heavier, a full balloon or an emptier one.
- Make tissue paper parachutes with string and clothespins.
- Drop a crumpled and a flat sheet of writing paper and watch which falls fastest. Explain the results.

SUN MAKES HEAT

- Go outside and stand in the sun with your eyes closed. Turn until you are facing the sun. Feel the heat on your skin. This is your skin absorbing the sun’s light and changing it into heat.
- Make “solar mittens” with aluminum foil on one side and black paper on the other. Wear them outside to feel which side heats up more.
- Put a white cloth and a dark cloth on a patch of snow in bright sun. Which melts the snow fastest?

THE WATER CYCLE

- Measure water into small cups and place some in a sunny window and others in various places in your classroom. Measure the evaporation rates, discuss the results.
- After a rain, place string around puddles to mark the perimeter and watch evaporation rates outside.
- Make terrarium cups with deli boxes or styrofoam and clear plastic cups. Watch the condensation form on the tops and discuss what is happening.
- Keep a weather chart. Track temperature, rainfall, snowfall, and winds. Discuss the difference between weather and climate. Find out your climate zone and yearly average rainfall.

INSTITUTE
for **GLOBAL**
ENVIRONMENTAL
STRATEGIES

2111 Wilson Boulevard
Suite 700
Arlington, VA 22201

*This material is based upon work supported
by NASA under grant No. NAG5-6974.*